

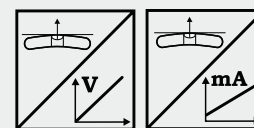

Analog Inclination Sensor for 1 axis or 2 axes in MEMS technology

- Measurement range $\pm 180^\circ$ for 1 axis or $\pm 60^\circ$ for 2 axes
- Protection class IP67 / IP69K
- Analog output linear
- Aluminium housing
- Wear free, high resolution
- High shock resistance
- Servo flange mounting



Specifications	Output	U2	Voltage 0.5 ... 10 V
		U8	Voltage 0.5 ... 4.5 V
	I1	Current 4 ... 20 mA	
Measurement range	$\pm 15 \dots \pm 180^\circ$ for 1 axis or $\pm 60^\circ$ for 2 axes		
Resolution	0.05°		
Linearity	$\pm 0.5^\circ$		
Settling time	0.1 s ... 10 s / 90 %, configurable		
Protection class	IP67/IP69K (connector output with IP69K connector cable)		
Material	Aluminium		
Connection	5 pin connector M12 axial or radial		
Shock (non-operational)	EN60068-2-27:2010, 100 g/11 ms, 100 shocks		
Vibration (non-operational)	EN60068-2-6:2008, 20 g/10 Hz-2 kHz, 10 cycles		
EMC, temperature	Refer to output specification		

Order code PTAM2



Model name

Axis of inclination

- 1 = Inclination in X axis (mounting X) $\leq \pm 180^\circ$
- 2 = Inclination in X and Y axis (mounting XY) $\leq \pm 60^\circ$

Measuring range [in °]

15 ... 180 = $\pm 15^\circ \dots \pm 180^\circ$ in increments of 15°

Output

- U2 = 0.5 ... 10 V
- U8 = 0.5 ... 4,5 V
- I1 = 4 ... 20 mA

Characteristic

- CW = Increasing signal for CW inclination
- CCW = Increasing signal for CCW inclination

Output delay 0 ... 90 %

Tx.x = 0.1 s ... 10 s

Connection

- M12R5 = 5-pin socket M12, radial (compatible with 4 pin mating connector)
- M12A5 = 5-pin socket M12, axial (compatible with 4 pin mating connector)

Order code connector cable (see page 10)

KAB-...M-M12/4F/G-LITZE

Order example: PTAM2 - 1 - 180 - I1 - CW - T1.0 - M12R5



Digital Inclination Sensor with 1 or 2 axes in MEMS technology

- Measurement range $\pm 180^\circ$ for 1 axis or $\pm 60^\circ$ for 2 axes
- Protection class IP67 / IP69K
- CANopen output
- Aluminium housing
- Wear free, high resolution
- High shock resistance
- Servo flange mounting

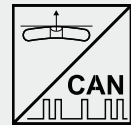

Specifications		
	Output	CANopen (profile „Inclination Sensor“)
	Measurement range	$\pm 180^\circ$ for 1 axis or $\pm 60^\circ$ for 2 axes
	Resolution	0.05 °
	Linearity	$\pm 0.5^\circ$
	Settling time	0.1 s ... 10 s / 90%, configurable
	Protection class	IP67/IP69K (connector output with IP69K connector cable)
	Material	Aluminium
	Connection	5 pin connector M12 axial or radial
	Shock (non-operational)	EN60068-2-27:2010, 100 g/11 ms, 100 shocks
	Vibration (non-operational)	EN60068-2-6:2008, 20 g/10 Hz-2 kHz, 10 cycles
	EMC, temperature	Refer to output specification

Order code PTDM2

Model name

Output

- CANOP = CANopen
- CANJ1939 = CAN SAE J1939

Connection

- M12R5/CAN = 5-pin socket M12, radial
- M12A5/CAN = 5-pin socket M12, axial

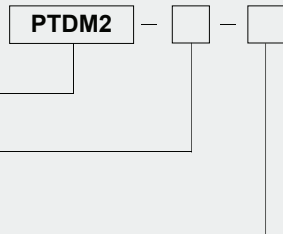

Order code connector cable (see page 11)

KAB - XM - M12/5F/G - M12/5M/G - CAN

Order example: PTDM2 - CANOP - M12R5/CAN

POSITILT®
PTAM2/PTDM2
Dimensions



Outline drawing
M12 radial

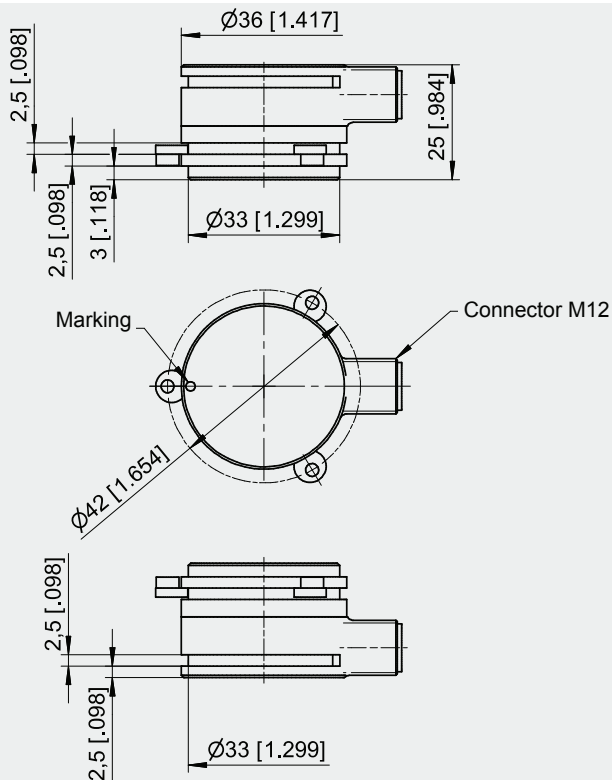

Dimensions in mm [inch]

Dimensions informative only.
 For guaranteed dimensions consult factory.

Outline drawing
M12 axial

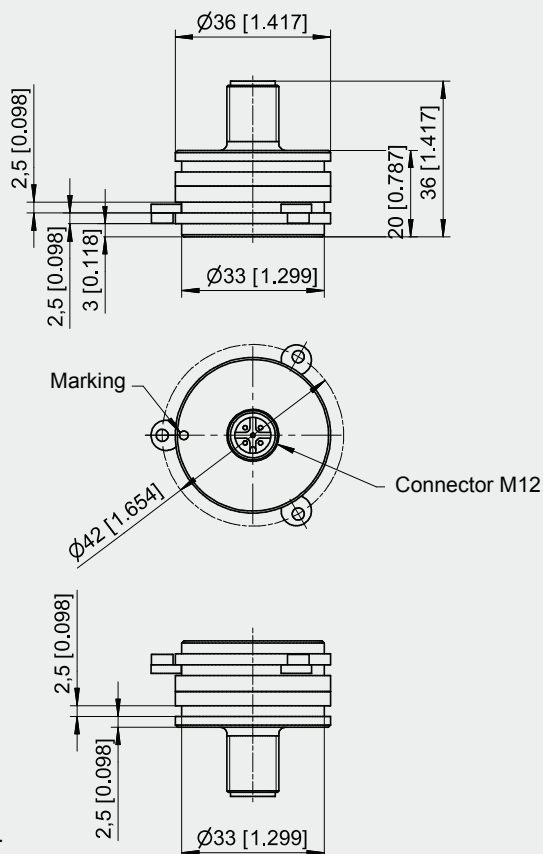

Dimensions in mm [inch]

Dimensions informative only.
 For guaranteed dimensions consult factory.

POSITILT®
PTAM2/PTDM2
Dimensions



Orientation of the
inclination axes

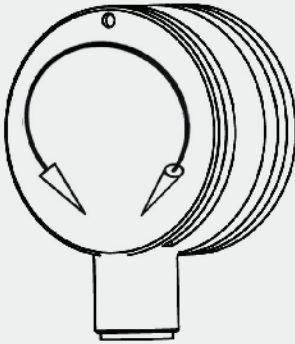

1 axis

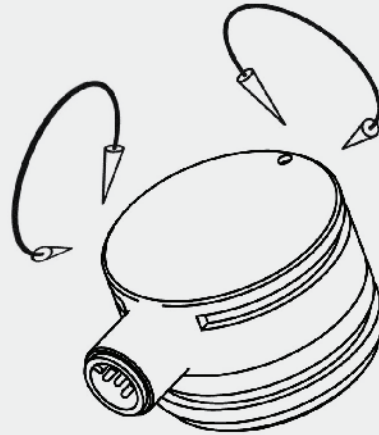

2 axes

U2 Voltage Output 0.5 ... 10 V 	Excitation voltage	18 ... 36 V DC
	Excitation current	12 mA typ., 16 mA max.
	Output voltage	0.5 ... 10 V DC
	Output current	2 mA max.
	Measuring rate	1 kHz standard
	Stability (temperature)	$\pm 100 \times 10^{-6} / ^\circ\text{C}$ f.s. (typ.)
	Operating temperature	-40 ... +85 °C
	Protection	Reverse polarity, short circuit
EMC	EN61326-1:2013	
U8 Voltage output 0.5 ... 4.5 V 	Excitation voltage	18 ... 36 V DC
	Excitation current	12 mA typ., 16 mA max.
	Output voltage	0.5 ... 4.5 V DC
	Output current	2 mA max.
	Measuring rate	1 kHz standard
	Stability (temperature)	$\pm 100 \times 10^{-6} / ^\circ\text{C}$ f.s. (typ.)
	Operating temperature	-40 ... +85 °C
	Protection	Reverse polarity, short circuit
EMC	EN61326-1:2013	
I1 Current Output 4 ... 20 mA 	Excitation voltage	18 ... 36 V DC
	Excitation current	32 mA typ., 36 mA max..
	Load resistor	500 Ω max.
	Output current	4 ... 20 mA
	Measuring rate	1 kHz standard
	Stability (temperature)	$\pm 100 \times 10^{-6} / ^\circ\text{C}$ f.s. (typ.)
	Operating temperature	-40 ... +85 °C
	Protection	Reverse polarity, short circuit
EMC	EN61326-1:2013	

Other outputs available on request.

Output signals

Connection

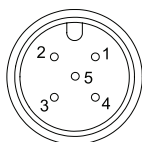

M12A5 / M12R5

View to sensor connector

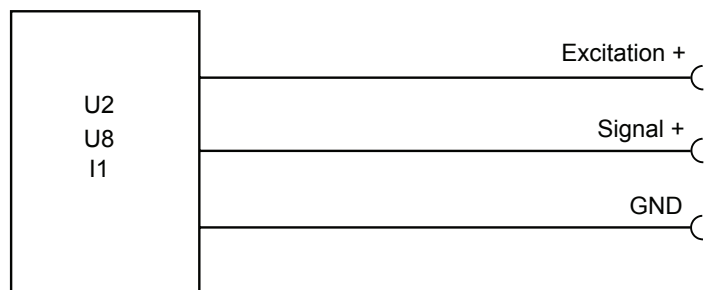

Signal Wiring	Output signals		Connector pin	Cable color
	1 axis	2 axes		
	Excitation +	Excitation +	1	brown
	Output X	Output X	2	white
	GND	GND	3	blue
	Do not connect!	Output Y	4	black
	Do not connect!	Do not connect!	5	gray

POSITILT[®]
PTDM
Output CANopen



Description Inclination sensor with CANopen interface according to CiA 410.

CANopen Interface 	Communication profile	CANopen CiA 301 V 4.02, Slave
	Device profile	Encoder CiA 410 V 1.2
	Configuration services	LSS, CiA Draft Standard 305 (transmission rate, node ID)
	Error Control	Node Guarding, Heartbeat, Emergency Message
	Node ID	Adjustable via LSS or via object dictionary, default: 127
	PDO	1 TxPDO, 0 RxPDO, static mapping
	PDO Modes	Event-/Time triggered, Remote-request, Sync cyclic/acyclic
	SDO	1 Server, 0 Client
	Certified	Yes
	Transmission rate	50 kBaud to 1 MBaud, adjustable via LSS or via object dictionary, default: 125 kBaud
	Bus connection	M12 connector, 5 pin
	Integrated bus terminating resistor	Optional
	Bus, galvanic isolation	No

Specifications	Excitation voltage	8 ... 36 V DC
	Excitation current	15/30 mA typical for 24/12 V, 100 mA max.
	Measuring rate	1 kHz standard
	Stability (temperature)	$\pm 100 \times 10^{-6} / ^\circ\text{C}$ f.s.
	Repeatability	1 LSB
	Operating temperature	-40 ... +85 °C
	Protection	Reverse polarity, short circuit
	EMC	EN61326-1:2013

POSITILT[®] PTDM Output CAN SAE J1939



Description Inclination sensor according to standard SAE J1939. Configuration of operating parameters by proprietary-A-Message (peer-to-peer connection). Process data exchange by proprietary-B-Message (broadcast).

Interface J1939 	CAN specification	ISO 11898, Basic and Full CAN 2.0 B
	Transceiver	24V-compliant, not isolated
	Communication profile	SAE J1939
	Baud rate	250 kbit/s
	Internal termination resistor	120 Ω
	Address	Default 247d, configurable

NAME Fields	Arbitrary address capable	1	Yes
	Industry group	0	Global
	Vehicle system	7Fh (127d)	Non specific
	Vehicle system instance	0	
	Function	FFh (255d)	Non specific
	Function instance	0	
	ECU instance	0	
	Manufacturer	145h (325d)	Manufacturer ID
	Identity number	0nnn	Serial number 21 bit

Parameter Group Numbers (PGN)	Configuration data	PGN EF00h	Proprietary-A (PDU1 peer-to-peer)
	Process data	PGN FFnnh	Proprietary-B (PDU2 broadcast); nn Group Extension (PS) configurable

Specifications	Excitation voltage	8 ... 36 V DC
	Excitation current	15/30 mA typical for 24/12 V, 100 mA max.
	Measuring rate	1 kHz standard
	Stability (temperature)	±100 x 10 ⁻⁶ / °C f.s.
	Repeatability	1 LSB
	Operating temperature	-40 ... +85 °C
	Protection	Reverse polarity, short circuit
	EMC	EN61326-1:2013

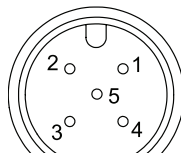
Signal wiring / connection	Signal name	Connector pin	View to sensor connector 
	Shield	1	
	Excitation +	2	
	GND	3	
	CAN-H	4	
	CAN-L	5	

POSITILT[®] Accessories Mounting Plates



PRPT-BPL1

(screw mounting)
For PTAM2 / PTDM2

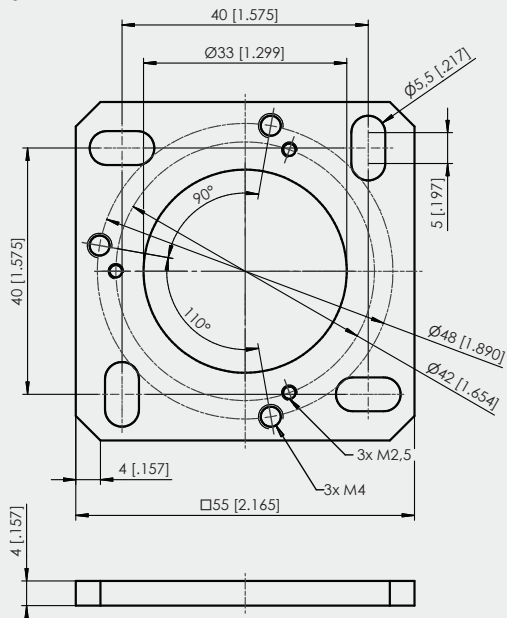

PRPT-BPL2

(welding assembly)
For PTAM2 / PTDM2

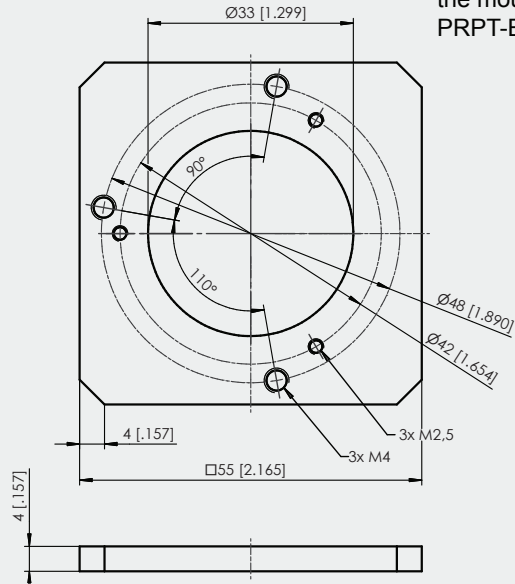

In combination with the
mounting clamps
PRPT-BFS1 (3 x M2.5)
or in combination with
the mounting brackets
PRPT-BFS2 (3 x M4)

Dimensions in mm [inch]

Weight 30 g approx.

Dimensions informative only.

For guaranteed dimensions please consult factory.

Mounting possibilities PTAM2/PTDM2

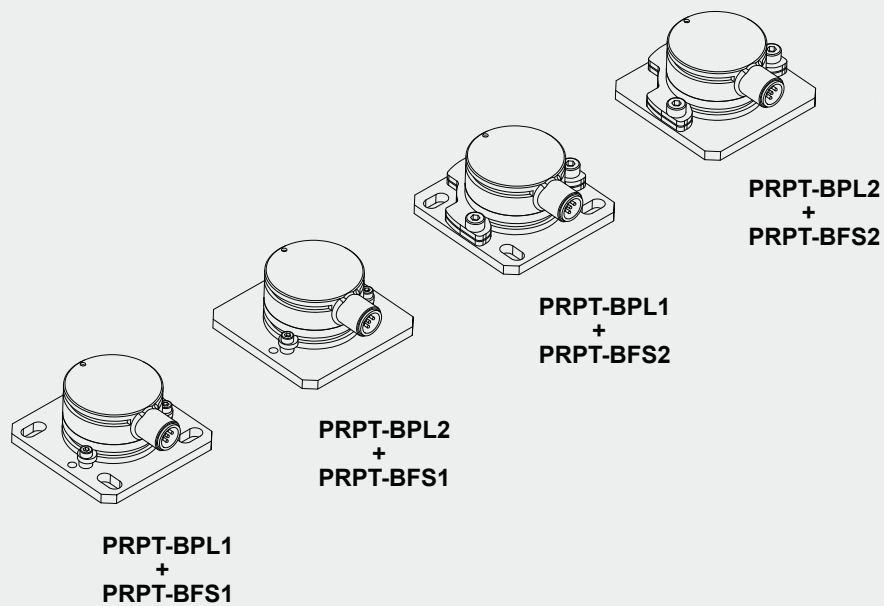

POSITILT[®]
PTAM/PTDM
Characteristic of the linear output



Output signal

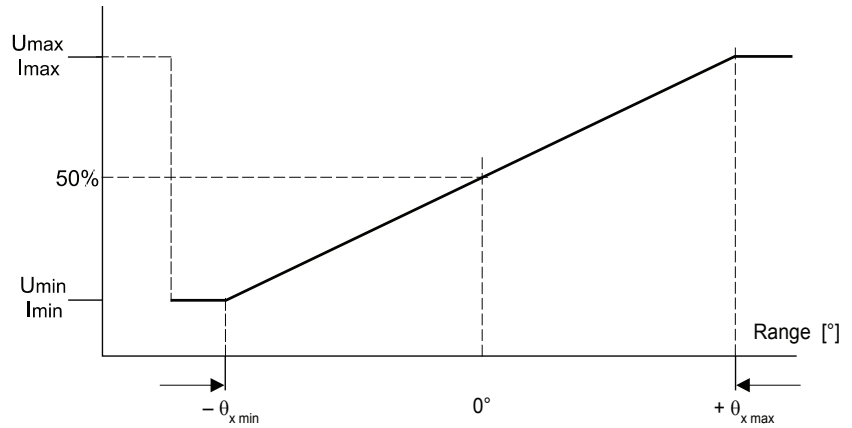

PTAM2/PTDM2

Radial, 1 axis

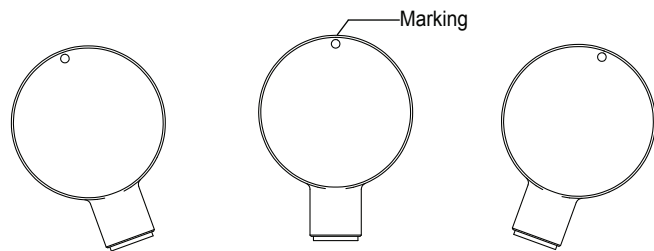

PTAM2/PTDM2

Radial, 2 axes

X

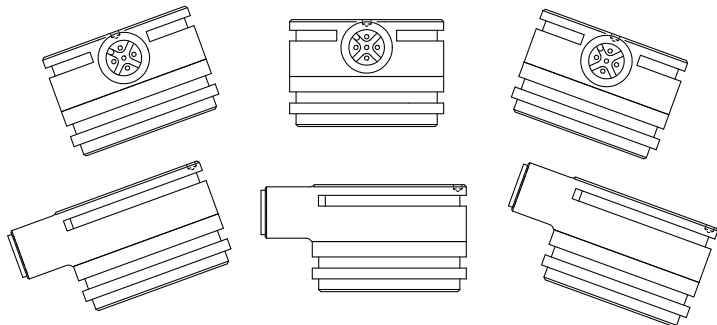

Y

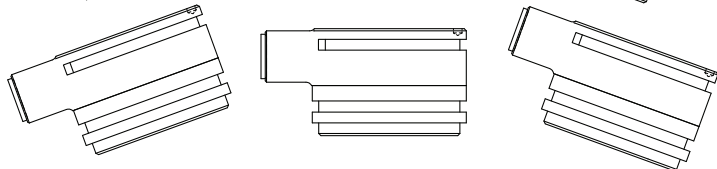

PTAM2/PTDM2

Axial, 1 axis

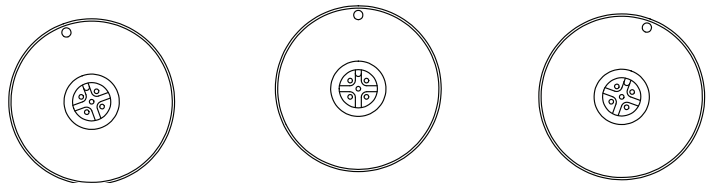

PTAM2/PTDM2

Axial, 2 axes

X

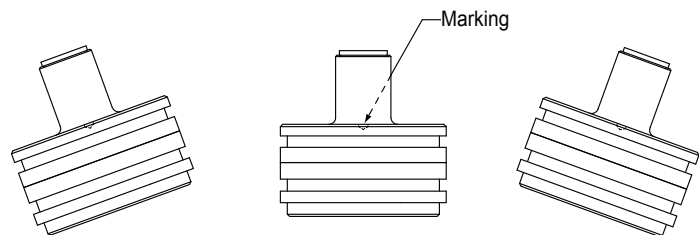

Y

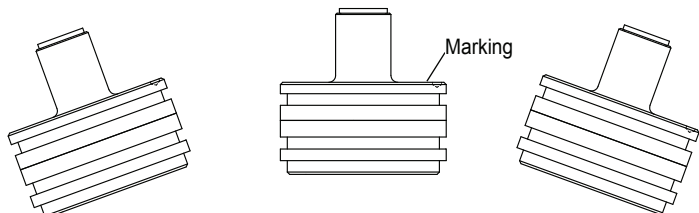

POSIROT® / POSITILT®

Accessories

Connector Cables



Connector cable for POSIROT®-POSITILT® sensors

4 pins M12

Suitable for 5-pin sensor connectors M12A5 and M12R5

The 4-core screened cable is supplied with a mating 4-pin 90° M12 connector at one end and 4 wires at the other end. Available lengths are 2, 5 and 10 m.

Order code:

KAB - XM - M12/4F/W - LITZE

IP69K: **KAB - XM - M12/4F/W/69K - LITZE**

Length in m

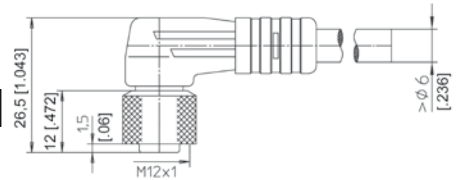
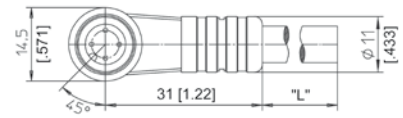

Connector cable for POSIROT®-POSITILT® sensors

4 pins M12

Suitable for 5-pin sensor connectors M12A5 and M12R5

The 4-core screened cable is supplied with a mating 4-pin M12 connector at one end and 4 wires at the other end. Available lengths are 2, 5 and 10 m.

Order code:

KAB - XM - M12/4F/G - LITZE

IP69K: **KAB - XM - M12/4F/G/69K - LITZE**

Length in m

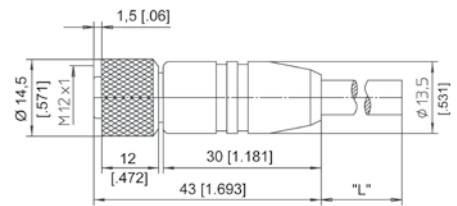

Signal wiring M12, 4 pin	Connector pin / cable color			
	1	2	3	4
Brown	White	Blue	Black	

**Connector/bus cable
for POSIROT®-
POSITILT® sensors**
5 pin M12
CAN bus

The 5-lead shielded cable is supplied with a female 5-pin M12 connector at one end and a male 5-pin M12 connector at the other end. Available lengths are 2, 5 and 10 m.

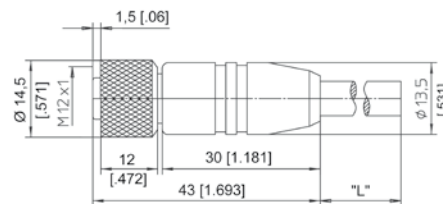

Order code:

KAB - XM - M12/5F/G - M12/5M/G - CAN

IP69K: KAB - XM - M12/5F/G/69K - M12/5M/G/69K - CAN

Length in m ↑

T-piece for bus cable
5 pin M12
CAN bus

Order code:

KAB - TCONN - M12/5M - 2M12/5F - CAN



**Terminating
resistance**
5 pin M12
CAN bus

Order code:

KAB - RTERM - M12/5M/G - CAN

