

MTL SD Modular range (Base unit)

Installation guide



MTL SD Modular range

Devices from the MTL SD Modular range are used to protect electronic circuits from high-voltage transients and temporary overloads on signal and power lines. This is achieved by diverting the transient current to ground and limiting the signal line voltage for the duration of the surge.

This base unit provides the connecting interface between the signal wiring and the protective plug-in module of the SD Modular range.

Grounding is provided by clipping the MTL SD Modular base to a DIN-rail that must be provided with a low impedance electrical path to ground. Terminals are also provided to connect cable screens to ground.

Installation

IMPORTANT - These devices are suitable for use in hazardous area circuits as described in IEC/EN60079-14. **Because of their intended safety function they must be removed when performing a 500V insulation test.**

Mount the MTL SD Modular base unit as follows (see Fig. 3):

- Hook the earthing clamp at the field side of the base unit over one flange of the DIN-rail (1).
- Press down the protected area end of the base unit firmly until it clicks into position (2).

Note: Check that the MTL SD Modular base unit is securely clamped into place on both field and protected sides. It is essential to check that the earth connection has been made securely.

To remove a device (see Fig. 3):

- Insert a screwdriver blade down the protected side (3) and lever the screwdriver handle gently against the MTL SD Modular base unit (4) until the spring clip disengages, allowing the base to be rotated away from the rail (5).

Grounding/Earthing

Correct grounding procedures are essential for effective and safe surge protection.

Note: This may require re-routing of the system earthing and the installation instructions should be checked carefully. If the system requires the DIN-rail to be isolated from the mounting plate then use ISP7000 insulating spacers (see Fig.4).

The suggested method of connection to the surge earth is using ETL7000 earth terminals clamped to the DIN- rail, preferably at, both ends of a row of MTL SD Modular surge protectors. Position the earth terminals close to the surge protection devices. (See Fig. 5).

Identification tags

The retention tag used to cover the top of the individual SD MTL SD Modular plug module is supplied fitted with an adhesive label that identifies the specific plug-in module fitted. The labels are also supplied in separate sheets for pre-printing by the user.

To fit a retention tag (see also Figure 6):

- Tilt the retention tag so that one side of the hinge can be engaged (1), then rotate over the top of the hinge to engage the other side (2).
- Close the retention tag and apply even pressure until it locks into place.

Fitting plug module

The following guidelines should be adopted during this process. (See also Figure 7)

- Lift the retention tag on the base unit carefully to allow the plug module to be inserted.
- Check the orientation of the plug module before inserting it into the base unit.
- Do not attempt to force the plug module into the base - check its orientation.
- Ensure the plug module is fully seated in the base unit.
- Close the retention tag and apply even pressure until it locks into place.

Cable connection to Base

SDM Bases are available with screw terminals and spring clamp terminals. The protection module marking shows the "field cable entry" and "protected equipment" side of the SPD.

When connecting the signal wires to a screw clamp base with an electric screwdriver the torque setting should be between 0.2Nm and a maximum of 0.4Nm

To connect signal wires to a spring clamp terminal, Please refer figure 1

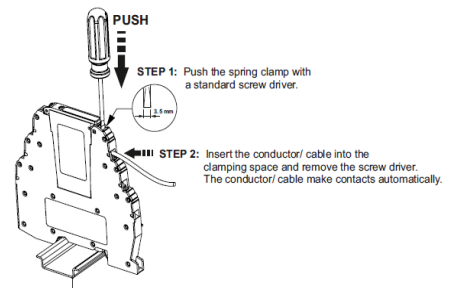

Figure 1: Connection to Spring clamp terminals

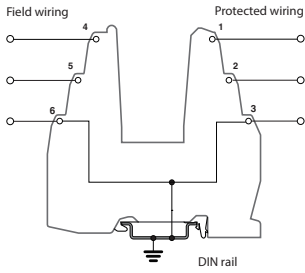

Figure 2: MTL SD Modular base unit

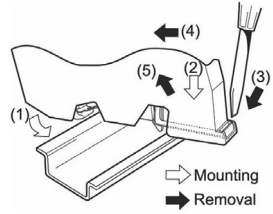

Figure 3: Mounting and removal of base unit

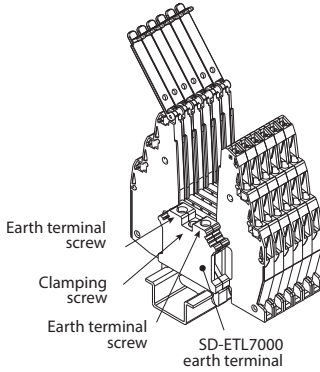

Figure 4: Fitting earth terminal

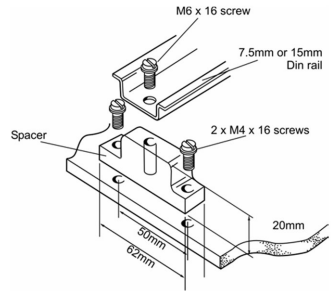

Figure 5: Mounting ISP7000 insulating spacer

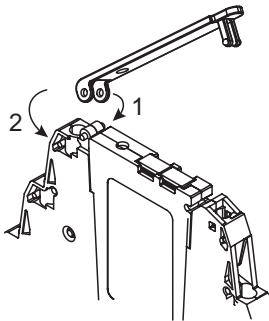

Figure 6: Fitting retention tag

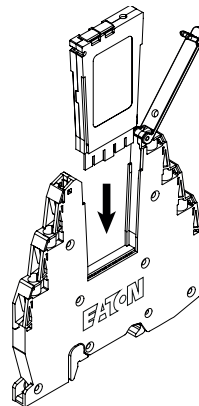

Figure 7: Plug module insertion

MTL SD Modular ATEX and IECEx Information (For Base with screw terminals)

The Essential Health and Safety Requirements (Annex II) of the EU Directive 2014/34/EU [the ATEX Directive - safety of apparatus] and the IECEx Scheme requires that the installation manual of all equipment used in hazardous areas shall contain certain information. This guide is included to ensure that this requirement is met. It complements the information presented in this document and does not conflict with that information. It is only relevant to those locations where the ATEX and IECEx directives are applicable.

1 General

a) In common with all other electrical apparatus installed in hazardous areas, this apparatus must only be installed, operated and maintained by competent personnel. Such personnel shall have undergone training, including instruction on the various types of protection and installation practices, the relevant rules and regulations, and on the general principles of area classification. Appropriate refresher training shall be given on a regular basis. [See clause 4.2 of EN 60079-17].

b) The apparatus has been designed and manufactured to satisfy the “essential health and safety requirements” of Annex II of the Directive.

c) This apparatus has been designed to meet the requirements of I.S. electrical apparatus in accordance with IEC/EN 60079-0, IEC/EN 60079-7 and IEC/EN 60079-11 and is normally mounted in the hazardous area.

d) This apparatus requires additional protection for use in dust environments.

2 Installation

a) The installation should comply with the appropriate European, national and local regulations, which may include reference to the IEC code of practice IEC 60079-14. In addition particular industries or end users may have specific requirements relating to the safety of their installations and these requirements should also be met. For the majority of installations the Directive 1999/92/EC [the ATEX Directive - safety of installations] is also applicable.

b) The apparatus must not be subjected to mechanical and thermal stresses in excess of those permitted in the certification documentation, this manual and the product specification. If necessary the product must be protected by an enclosure to prevent mechanical damage.

c) The apparatus must not be installed in a position where it may be attacked by aggressive substances and must be protected from excessive dust, moisture and other contaminants by an enclosure.

d) This apparatus is I.S. electrical apparatus and is normally mounted in a hazardous area. It meets the requirements of Category 1 apparatus and may be installed in a Zone 0 location providing that the relevant installation conditions are met.

3 Inspection and maintenance

a) Inspection and maintenance should be carried out in accordance with European, national and local regulations which may refer to the IEC standard IEC 60079-17. In addition specific industries or end users may have specific requirements which should also be met.

b) If the outer enclosure of the apparatus needs to be cleaned, this should be done with a cloth lightly moistened by a dilute mixture of detergent in water.

4 Special Conditions for Safe Use (Ex ia applications)

a) The plastic enclosure may present an electrostatic risk and must not be rubbed in service.

b) The range of SDBE-B** Series Surge Protection Devices will not meet the 500V insulation requirements to earth; therefore suitable precautions must be taken when installing the apparatus.

5 Special Conditions for Safe Use (Ex ec applications)

a) The equipment shall only be installed in an area of at least Pollution Degree 2, as defined in IEC 60664-1, and in an enclosure that

provides a degree of protection of at least IP54 and meets the relevant requirements of IEC 60079-0 & IEC 60079-7.

b) The equipment may not be capable of withstanding the 500V dielectric strength test in accordance with clause 7.1 of IEC 60079 7, and this must be taken into account during installation.

c) All pluggable connections between the module and base, and where fitted, the disconnect or fuse links must not be inserted or removed

unless the area in which the equipment is installed is known to be non-hazardous, or the circuit to which it is connected has been de-energised.

d) Unused terminals on the equipment shall be tightened

6 Repair

This product cannot be repaired by the user and must be replaced with an equivalent certified product.

7 Marking

Each certified product variant is marked in compliance with the Directive and CE marked with the Notified Body Identification Number. This information applies to products manufactured during or after the year 2012.

The SD Modular range has both Ex ia and Ex ec approvals. Once a product has been used in a non-IS Ex ec application, it must not subsequently be used in an IS application. A check box is present next to the certification marking on the label. The protection concept used should be marked on the product.

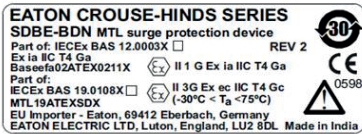

Example of label markings

For more information please contact your local office for Eaton's MTL product range or visit...

www.mtl-inst.com



Eaton Electric Limited,
 Great Marlings, Butterfield, Luton
 Beds, LU2 8DL, UK.
 Tel.: +44 (0)1582 723633 Fax: +44 (0)1582 422283
 E-mail: mtlenquiry@eaton.com
www.mtl-inst.com

© 2020 Eaton
 All Rights Reserved
 Publication No. INS 801-752 Rev 2 201020
 October 2020

EUROPE (EMEA):
 +44 (0)1582 723633
mtlenquiry@eaton.com

THE AMERICAS:
 +1 800 835 7075
mtl-us-info@eaton.com

ASIA-PACIFIC:
 +65 6645 9864 / 9865
sales.mtising@eaton.com

The given data is only intended as a product description and should not be regarded as a legal warranty of properties or guarantee. In the interest of further technical developments, we reserve the right to make design changes.