

Product specification

switch-mode power supply: SNT5024

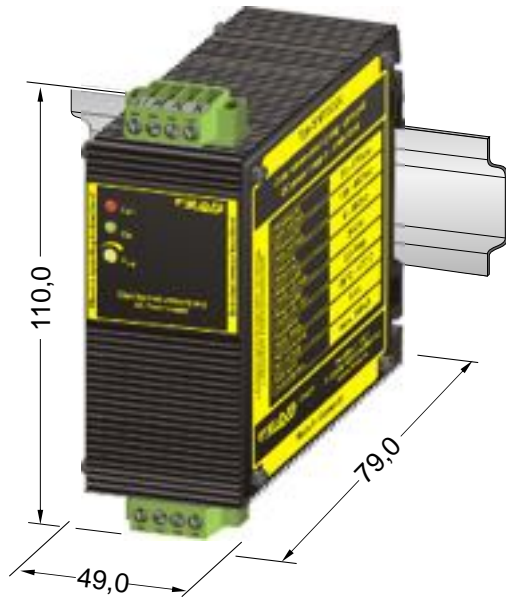

CE compliant

- Regulated output voltage
- Output separated according to VDE0551
- Extra low safety potential
PELV (EN 50178) SELV (EN 60950)
- Overload- and open circuit protected
short circuit proof
- Parallel operation possible to increase output power
- Operating status shown by LED
- Simple mounting on rail acc. to DIN 46277
or wall mounting with screws
- Suitable for the tropics - epoxy resin casted
- Conforms to EMC and low voltage directive
- Input voltage 85 - 270 V_{AC} or 120 - 400 V_{DC}
- Output adjustable 22.5 - 30.0V_{DC}

Application

The switch-mode power supplies of the SNT5024 series are powerful and robust devices to power sensitive loads in a hard industrial environment.

These features result from the modern construction with a good radio shielding and high reliability integrated in a functional and stable casing.

The short circuit proof output DC voltage of this model can be adjusted from 22.5 to 30.0 V.

This power supply is optimally suited for loads requiring high starting currents.

Functional principle

In the power supply SNT5024 a flyback converter operates to transform the energy in two steps.

During the conducting phase the diode is blocking, the inductor is energized and a magnetic field establishes. There is no electrical transmission; the consumer load is supplied with energy from the capacitor.

When the switching transistor opens, the blocking phase begins. The current in the inductor cannot change immediately, discharges through the diode and a negative voltage establishes at the inductor.

Now operating like a power source the inductor reloads the capacitor and supplies the consumer with energy.

The energy flows from the inductor into the capacitor and the consumer and through the conducting diode back to the inductor.

Design

Completely embedded with resin in an aluminium housing for mounting on a rail or wall mounting with screws.

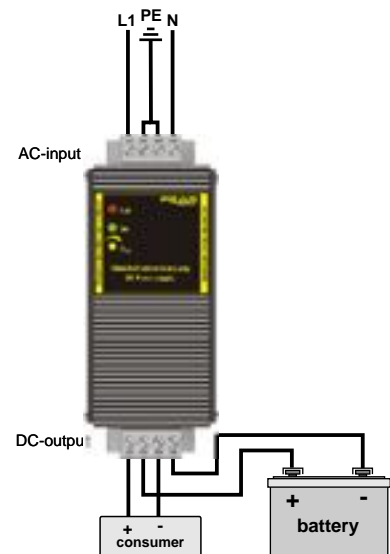

optional accumulator in parallel operation

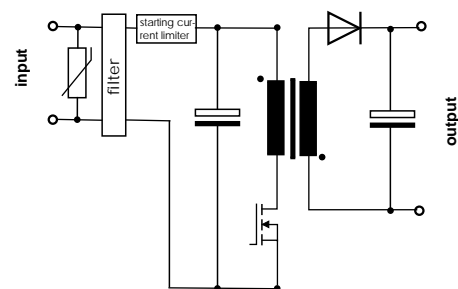

 Please read the data sheets and the operating instructions for further information.

FEAS

P.O. Box 1521
D - 22905 Ahrensburg

Phone: +49 4102 42082
Fax: + 49 4102 40930

e-mail : contact@feas.com
Internet: www.feas.com