

Submersible level and temperature transmitters

ATM/N/T



Version: 12.01.2015

Technical Specifications

Pressure measuring range (mH2O)

	1 ... 5, (1)	> 5 ... 20	> 20 ... 250
Overpressure	3 bar	3 x FS (min. 3 bar)	3 x FS
Burst pressure	> 200 bar	> 200 bar	> 200 bar
Accuracy, (2), (\pm % FS)	$\leq 0.5 / \leq 0.25$	$\leq 0.5 / \leq 0.25 / \leq 0.1$	$\leq 0.5 / \leq 0.25 / \leq 0.1$
Thermal shift, (\pm % FS/$^{\circ}$C)			
Zero point -5 ... 50 $^{\circ}$ C	≤ 0.06	≤ 0.03	≤ 0.03
Span -5 ... 50 $^{\circ}$ C	≤ 0.015	≤ 0.015	≤ 0.015
Response time, (typ.)	< 1ms / 10 ... 90% FS	< 1ms / 10 ... 90% FS	< 1ms / 10 ... 90% FS
Long term stability, (3)	< 0.5% FS / < 4 mbar	< 0.2% FS / < 4 mbar	< 0.1% FS / < 0.2% FS

(1) 0.5 mH2O on request

(2) Zero based accuracy according to DIN-16086, incl. hysteresis and repeatability at ambient temperature

(3) 1 year (typ. / max.), the long term stability can be improved by ageing (burn-in) the sensor

Temperature measuring range

Standard, (1)	-5 ... 80 $^{\circ}$ C
Lower end of range	-25 $^{\circ}$ C
Upper end of range	85 $^{\circ}$ C
Temperature span, (2)	> 30 $^{\circ}$ C
Accuracy, (3)	
0 ... 70 $^{\circ}$ C, (typ. / max.)	$\pm 0.5 / 1.0$ $^{\circ}$ C
-25 ... 85 $^{\circ}$ C, (typ. / max.)	$\pm 1.0 / 1.5$ $^{\circ}$ C

(1) Other temperature measuring ranges on request

(2) Measuring range 15...30 $^{\circ}$ C must be contained

(3) Probe, electronics, calibration

Temperature range

Operating temperature	-5 ... 80 $^{\circ}$ C
Process temperature	-5 ... 80 $^{\circ}$ C
Storage temperature	-10 ... 80 $^{\circ}$ C

Electrical specifications

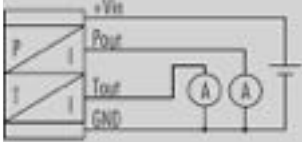
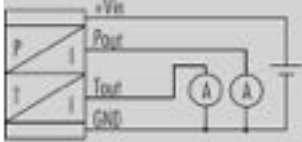
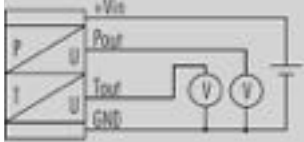
	4 ... 20 mA	0 ... 20 mA	0 ... 5 V / 0 ... 10 V
Power supply	15 ... 30 VDC	15 ... 30 VDC	15 ... 30 VDC
Supply influence	< 0.1% FS	< 0.1% FS	< 0.1% FS
Current consumption			3 mA
Circuit diagram			
Load resistance	$(U_b - 5V) / 0.02A$	$(U_b - 5V) / 0.02A$	$R_L > 10k\Omega$
Load influence	< 0.1% FS	< 0.1% FS	< 0.1% FS

Qualifications

	Description	Level	Typical interferences
EN 61000-4-2	Electrostatic discharge	4 kV contact 8 kV air	
EN 61000-4-3	Irradiated RF	10V/m (0.08 ... 1 GHz, 3s)	Radio sets, wireless phones
EN 61000-4-4	Transients (burst)	2 kV	Motors, valves
EN 61000-4-6	Conducted RF	10 V (0.15 ... 80 MHz, 3 s)	Frequency converters

Physical specifications

Materials	
Transducer	Stainless steel (316L / 1.4435), titanium (Gr. 2), (1)
Housing	Stainless steel (316L / 1.4404), titanium (Gr. 2)
Seals	Viton (Standard), EPDM, Kalrez
Cable	PUR, FEP, PE

Equipment

Overview

10.00.0091	Accessories overview

Additional documents

Operating and safety instructions

	Article number
10.88.0092	DMM029

Ordering information

		X. XXXX.	XXXX.	XX.	XXX
Type	ATM/N/T	31			
Pressure type	Gauge	1			
	Absolute (vacuum)	2			
Pressure measuring range	50 mbar ... < 100 mbar	XX			
	100 mbar ... 25 bar	XX			
	Offset, special adjustment	99			
Process connection	Closed (Fig. 1)	55			
	Open (Fig. 2)	56			
	Customized	99			
Electrical connection	PE cable, black, IP 68 (4) (5)		13		
	PUR cable, black, IP 68 (4) (6)		15		
	FEP cable, black, IP 68 (4)		21		
	Connectable version, IP 68, Lumberg RSF4 (Fig. 4), (3)		07		
	Customized		99		
Output signal	0 ... 5 VDC		46		
	0 ... 10 VDC		47		
	0 ... 20 mA		00		
	4 ... 20 mA		05		
	Customized		99		
Accuracy	$\leq \pm 0.5$ % FS			0	
	$\leq \pm 0.25$ % FS			1	
	$\leq \pm 0.1$ % FS			2	
Temperature range	-5 ... 50°C compensated (allowed process temperature: -5 ... 50°C)			4	
	-5 ... 80°C compensated (allowed process temperature: -5 ... 80°C)			5	
Option 1	Special oil filling: Anderol Food (for food applications)				G
Option 2	Electronics packed in gel: Absolute pressure				D
Option 3	Ballast weight 1.4435				B
	Cutting ring connection G 1/2 M				
	Strain relief				
	Version titanium (without ballast weight)				K
	Seals: Viton (standard)				U
	Seals: EPDM				S
	Seals: Kalrez (Level)				T
	Humidity filter element for gauge versions (only for PUR and PE cable)				Z

(1) 0.5 mH₂O on request

(2) mH₂O, mWS, mWC etc. available

(3) Connector with required cable has to be ordered separately (KART100)

- (4) Please specify the required cable length and medium
- (5) Suitable for drinking water (food approved)
- (6) For operating temperature > 50°C, PE or FEP cable must be used
- (7) min. Medium temperature -25 ° C
- (8) Standard, no special cleaning. Special cleaning must be requested.

Technical drawings

Dimensions

Fig. 1: Closed version

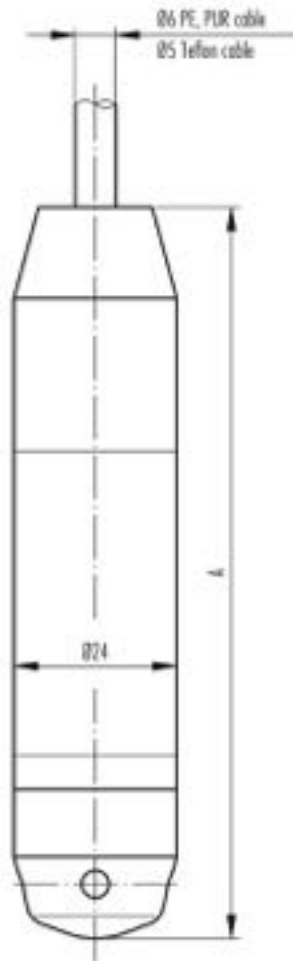

Fig. 2: Open version

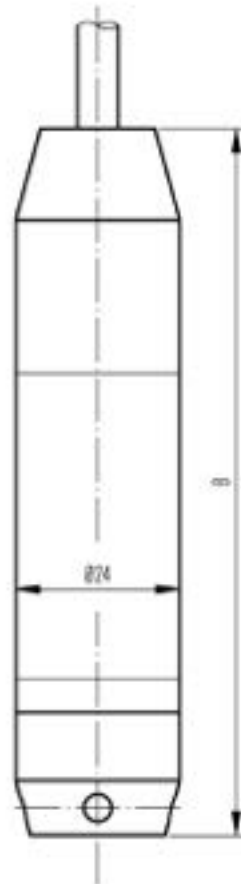

Fig. 3: with process connection

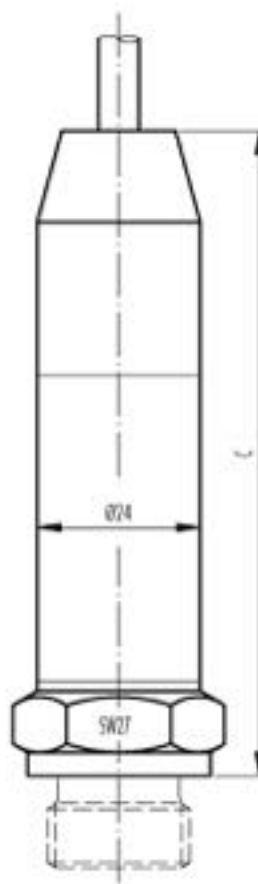
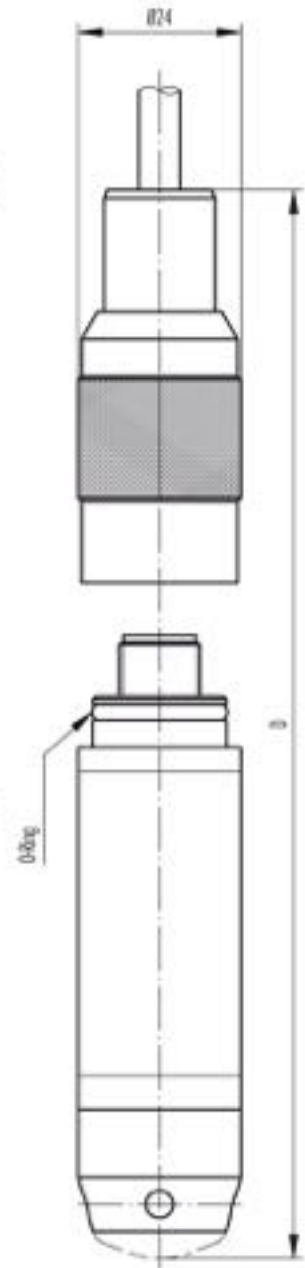

Fig. 4: Electrical connection, connectable



Standard

	A (mm)	B (mm)	C (mm)	D (mm)	Weight (g)
without ballast weight	137	133	on request*	on request*	approx. 180
with ballast weight	224	220	on request*	on request*	approx. 440

*C: depending on process connection

*D: depending on process connection or version

Colour: 4-Wire

white +Vin
yellow GND
brown Fout
green Tcut



Specifications may change without notice.

ST5 Headquarters, Switzerland
ST5 Sensor Technik Simach AG
Rütholstrasse 8, 8370 Simach, Switzerland
sales@st5sensors.com | www.st5sensors.com

ST5 France
ST5 France
844 Route de la Caillie, 74350 Allonzier-la-Caille, France
info-fr@st5sensors.com | www.st5sensors.fr

ST5 Germany
ST5 Sensoren Transmitter Systeme GmbH
Poststrasse 7, 71063 Sindelfingen, Germany
info-de@st5sensors.com | www.st5sensors.de

ST5 Great Britain
ST5 Great Britain Ltd
Box 2942 | Warwick | CV34 9AE, United Kingdom
contact@st5sensors.com | www.st5sensors.co.uk

ST5 Italy
ST5 Italia s.r.l.
Via Gesù 5, 20090 Opera (Milano), Italy
info-italia@st5sensors.com | www.st5sensors.it