

Pulse Transducer - contactless

DK according to NAMUR-EN 50227

EOG opto-electronic

Leaflet No. **Kiepe 115**



APPLICATION

Operation of Pulse Transducers, type DK and EOG, is contactless. 1 or 5 pulses/revolution can be generated from the DK device. The Pulse Transducers of type EOG generate 1, 5, 10 or 25 pulses/revolution.

The transducer's shaft has to be coupled to the shaft of the monitored drive. The use of the DK/EOG Pulse Transducers is recommended in all cases where it is impossible either to install pulse discs or to utilize other rotating machine parts for pulse generating purposes. The Pulse Transducer DK contains an inductive slot initiator, which is energized by a pulse disc with 1 or 5 targets.

The correct operation of the Kiepe Pulse Transducer EOG is only guaranteed in conjunction with Kiepe Electronic Speed Monitors EDO and JMNC. The opto-electronic transducer produces extremely step-front pulses.

The high accuracy of the pulse disc guarantees exact spacing, even when 25 pulses/revolution are generated.

Depending on the selection made, the transducers can produce from 1 to 25 pulses per revolution of the shaft. The use of this opto-electronic transducer is recommended, if high accuracy at the switching point of the speed control system is required.

The opto-electronic Transducer EOG 025 is especially designed to monitor drives at standstill. The transducer's voltage feed is supplied by the Kiepe Speed Monitor. Therefore, the Transducers EOG require a 3-core connecting cable (e.g. 3 x 2,5 mm²).

Combined with the Kiepe Belt Drive type B, a direct control of the conveyor belt run is obtained. A reliable slip control prevents the conveyor belt from being damaged.

COUPLINGS

K1

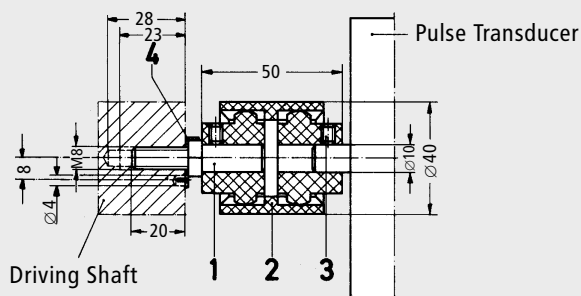

Order number: 94.040 535.001

Flexible plastic coupling, temperature range about -25 °C bis +100 °C, weatherproof, maximum misalignment 3 mm

- 1) Connecting shaft
- 2) Coupling
- 3) M5 x 6 Grub screw
- 4) 8,4 Locking washer

K6

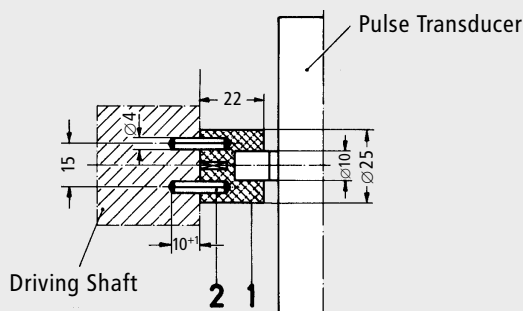

Order number: 96.040 535.002

Two-pin rubber coupling, oil-resistant, maximum misalignment 2 mm

- 1) Coupling
- 2) Roll pin 4 x 20

K7

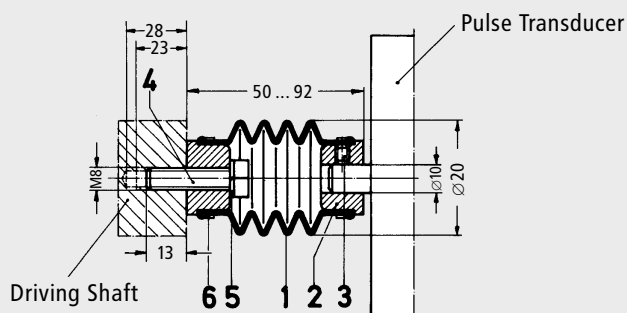

Order number: 94.040 535.004

Flexible bellows coupling suitable for poor misalignment, maximum misalignment 10 mm

- 1) Bellows
- 2) Fixing collar
- 3) M5 x 6 Grub screw
- 4) Hexagon M8 x 30 screw
- 5) Spring retaining ring B8
- 6) Retaining strap

TECHNICAL DATA

Pulse Transducer DK

Device complies with	NAMUR - EN 50227 EN 50081-1 EN 50082-2 EN 50178-94
Ambient temperature	-25 °C ... +70 °C
Connection	Via a terminal block (+ brown, - blue)
Operation position	Any
Cable entry	2 plastic stoppers maximum 3 x 2,5 mm ² for DK, 1 x M25 x 1,5 for DK/S and DK/GG
Protection	DK = IP 54/DKS* or DK/GG* = IP 65 according to EN 60529
Maximum operational speed	2500 min ⁻¹ (DK 155), 5000 min ⁻¹ (DK 111)

* Housing material: S = Aluminium, GG = Cast iron

OPERATION PRINCIPLE

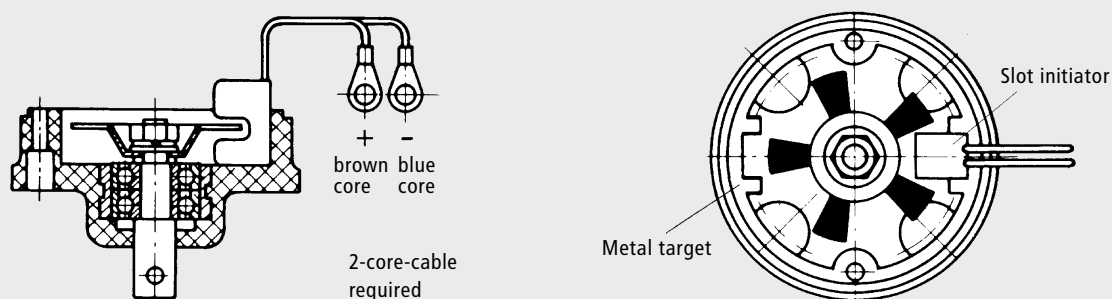

TECHNICAL DATA

Pulse Transducer EOG

Device complies with	EN 50081-1 EN 50082-2 EN 50178-94
Supply voltage	24 V = +10% -15% or 15 V = +10% -15%
Ambient temperature	-20 °C ... +70 °C
Protection	EOG = IP 54/EOGS* or EOG/GG = IP 65 according to EN 60529
Cable entry	2 plastic stoppers maximum 3 x 2,5 mm ² for EOG, 1 x M25 x 1,5 for EOG/S and EOG/GG
Maximum impulse amplitude	40 V
Maximum impulse current	6 mA
Maximum impulse frequency	18.000 min ⁻¹ , = 300 cyc.
Pulse accuracy	± 1 % at constant RPM
Maximum operational speed	5000 RPM

* Housing material: S = Aluminium, GG = Cast iron

CONNECTION DIAGRAM

Without cover, 3-core-cable required

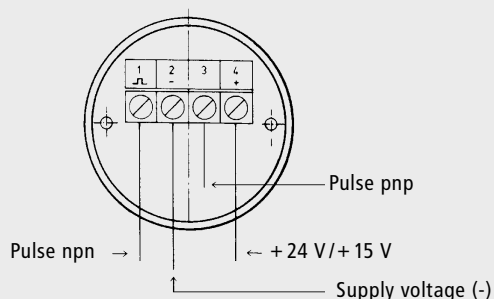

SELECTION TABLE

Type	No. of energized pulses per revolution	Type	No. of energized pulses per revolution
DK 111	1	EOG 001	1
DK 155	5	EOG 005	5
		EOG 010	10
		EOG 025	25

When used in conjunction with the conveyor monitor type B the operating speed can be converted into rpm by the following formulae:

$$\text{Rev./min.} = \frac{\text{Belt speed in meter/sec.} \times 60}{0,314}$$

MOUNTING DETAILS AND ORDERING CODES

Pulse Transducer, basic version
Protection to IP 54

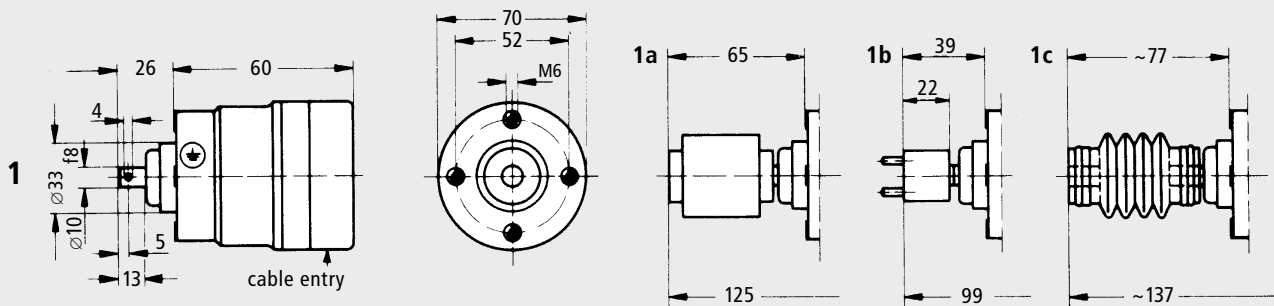

	DK/EOG	Type number	Type of casing	Type of mounting	Type of coupling
1			-1		
1a			-1		/K1
1b			-5		/K6
1c			-1		/K7

Pulse Transducer, basic version with foot mounting F3,
Protection to IP 54

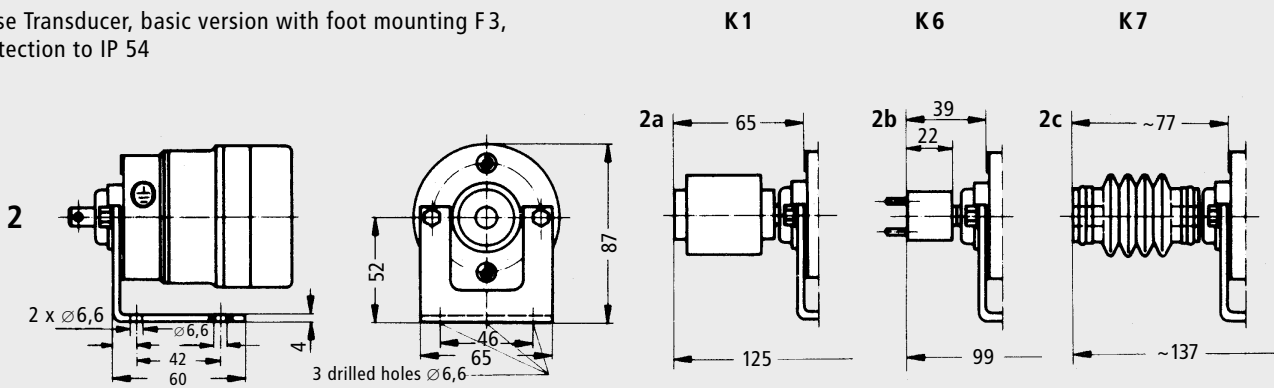

	DK/EOG	Type number	Type of casing	Type of mounting	Type of coupling
2			-1	/F3	
2a			-1	/F3	/K1
2b			-5	/F3	/K6
2c			-1	/F3	/K7

MOUNTING DETAILS AND ORDERING CODES

Pulse Transducer in aluminium case type S or in cast iron casing GG,
Protection to IP 65

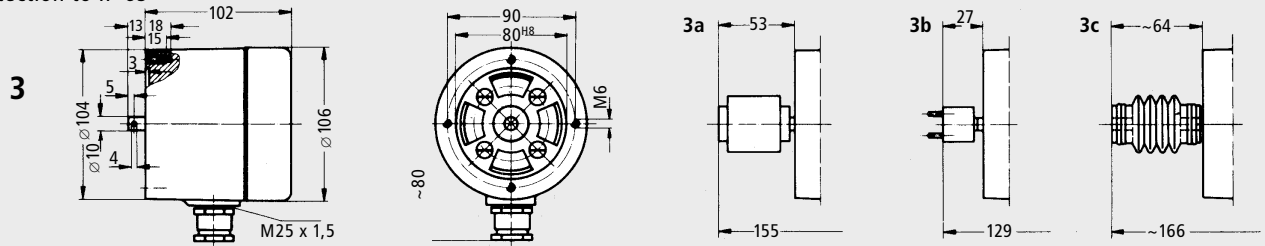

DK/EOG	Type Number	Type of casing	Type of mounting	Type of coupling
--------	-------------	----------------	------------------	------------------

3		-2	/S	
3a		-2	/S	/K1
3b		-3	/S	/K6
3c		-2	/S	/K7

Pulse Transducer in aluminium case type S with foot mounting F4,
Protection to IP 65

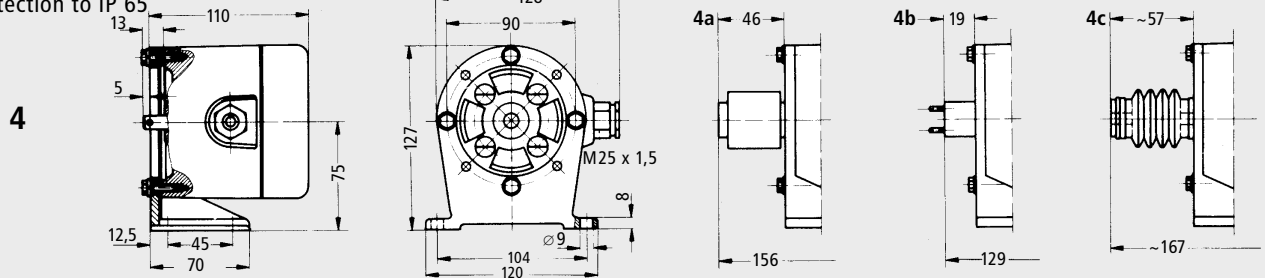

DK/EOG	Type Number	Type of casing	Type of mounting	Type of coupling
--------	-------------	----------------	------------------	------------------

4		-2	/S	/F4
4a		-2	/S	/K1
4b		-3	/S	/K6
4c		-2	/S	/K7

Pulse Transducer in aluminium case type S with mounting flange F1,
Protection to IP 65

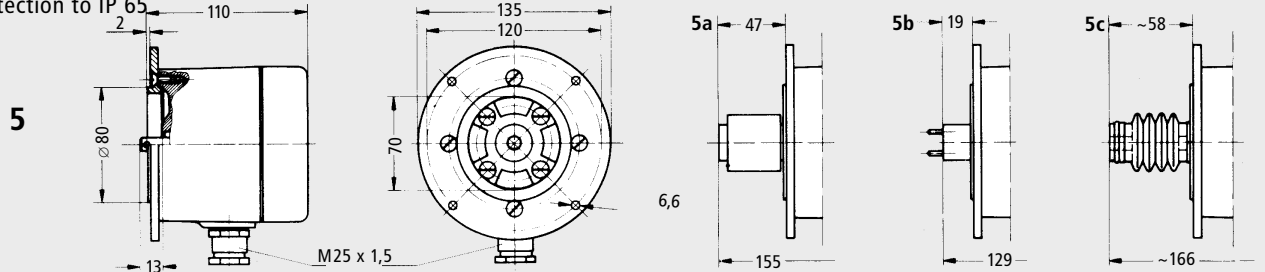

DK/EOG	Type Number	Type of casing	Type of mounting	Type of coupling
--------	-------------	----------------	------------------	------------------

5		-2	/S	/F1
5a		-2	/S	/K1
5b		-3	/S	/K6
5c		-2	/S	/K7

Pulse Transducer in aluminium case type S with mounting flange F2,
Protection to IP 65

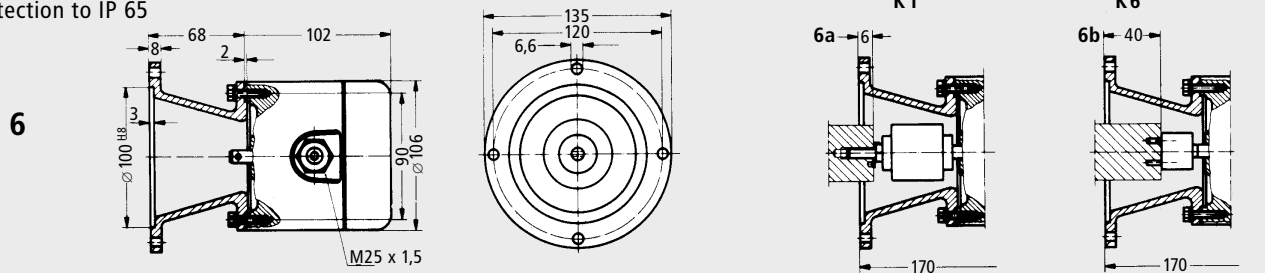

DK/EOG	Type Number	Type of casing	Type of mounting	Type of coupling
--------	-------------	----------------	------------------	------------------

6		-2	/S	/F2
6a		-2	/S	/K1
6b		-3	/S	/K6

DIMENSIONS AND ORDERING CODES

Pulse Transducers Type DK/EOG, Housing S or GG with Belt Drive Protection to IP 65

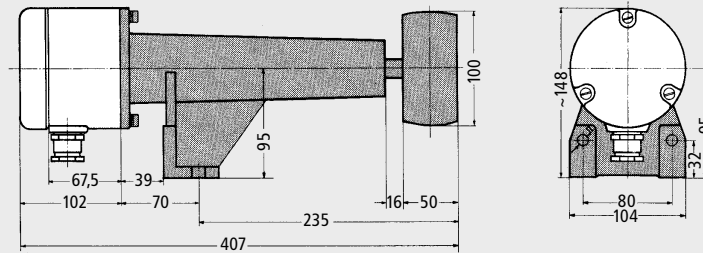

Ordering Code

for Belt Drive with inductive NAMUR-Pulse Transducer DKB

Type number	Housing ¹⁾	Roller ²⁾
DKB	-2 /S	/K
DKB	-2 /S	/G
DKB	-2 /GG	/K
DKB	-2 /GG	/G

Ordering Code

for Belt Drive with opto-electronic Pulse Transducer EOGB

Type number	Housing ¹⁾	Roller ²⁾
EOGB	-2 /S	/K
EOGB	-2 /S	/G
EOGB	-2 /GG	/K
EOGB	-2 /GG	/G

¹⁾ S: Aluminium, GG: Cast iron

²⁾ G: Rubber, K: Plastic

DIMENSIONS

Hinge Pedestal Type GB
to be fitted on Belt Drive B

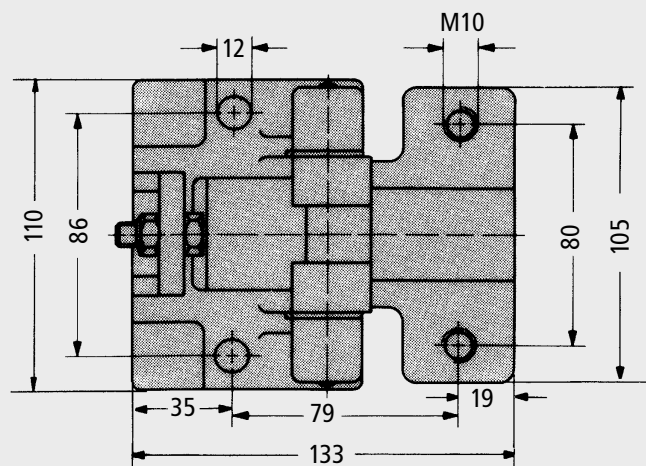
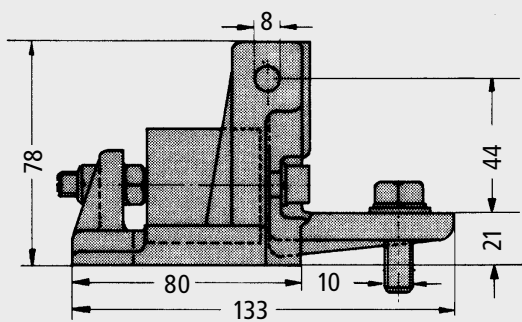

Type G



Type K

The use of the hinge pedestal is recommended to ensure constant pressure between belt and roller in order to avoid failures caused by slip.

The extent of supply of the belt drive comprises rubber or plastic rollers.

Subject to change without notice.

Vossloh Kiepe GmbH

D-40599 Düsseldorf (Germany) · Kiepe-Platz 1
Phone +49(0)211 74 97-0 · Fax +49(0)211 74 97-420
info@kiepe-elektrik.com · www.kiepe-elektrik.com

115/2-02/09